

Whistler

ASSEMBLY MANUAL

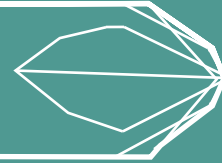

TABLE OF CONTENTS

Introduction	1	Assembly	8
		Handlebar Installation	
		Front Wheel Installation	
		Pedals Installation	
		Pump Tires	
General Warnings	4		
The Total Package	5	About the Battery	14
		General Overview	
		Maintenance	
		Storage	
		Charging and Handling	
		Inserting and Removing Battery	
		Charging Procedure	
		Checking State-of-Charge	
Owner's Identification	6		
Recommended Tools	7		

Hello

Thank you for choosing eProdigy Bikes. It is our mission to provide you with the latest in electric propulsion technology, and inspire the joy of riding worldwide one cyclist at a time. Your *Whistler* is designed with some of the most innovative industry thinking to provide you with the safest, most efficient and thrilling experience. Should there be any time you are unsure about the maintenance or service process please contact your dealer for immediate assistance. We hope you enjoy your new electrical assist bicycle, as much as we love to ride ours.



IMPORTANT: This document is meant to be used in conjunction with the *eProdigy User Manual* please read this *Whistler Assembly Manual* together with the User Manual carefully to protect yourself, your bike and to ensure you safely enjoy the full performance of the product.

Note: It is strongly recommended to have your bicycle examined by a professional mechanic prior to riding.

eProdigy Technical Support can be reached by email at support@eProdigyBikes.com or by phone at **1-888-928-9328 ext. 2**

GENERAL WARNING

This manual contains numerous “cautions” and “warnings”, please pay attention to these as they directly impact either the proper use of the bicycle, avoiding potentially hazardous situations, or general safety. The **WARNING** labels must be paid special regard to, failure to do so may result in serious injury or death.

- The combination of the safety alert symbol  and the word **WARNING** indicates a potentially hazardous situation which, if not avoided, could result in serious injury or death.
- The combination of the safety alert symbol  and the word **CAUTION** indicates a potentially hazardous situation which, if not avoided, may result in minor or moderate injury, or is an alert against unsafe practices.
- The word **CAUTION** used without the safety alert symbol indicates a situation which, if not avoided, could result in serious damage to the bicycle or rendering of your warranty void.
- Do not add a motor to the product.
- Do not tow the product.
- Do not modify the product.
- Replace worn or broken parts immediately.
- If anything does not operate properly, discontinue use.

THE TOTAL PACKAGE

Check that your eProdigy package is correct, complete, and undamaged.

Your eProdigy package should contain the following:

- 1 eProdigy Bicycle frame
with a Coaxial Bottom Bracket Motor™ installed
- 2 Rear wheel
- 3 Downtube battery mount
with 2 keys installed
- 4 Handlebars with KT-LCD3 control panel
display, throttle, shifter, and grips installed
- 5 Front wheel
- 6 Seat Post with saddle installed
- 7 Pedals
- 8 Quick Release for the Front wheel
- 9 Front + Rear fenders

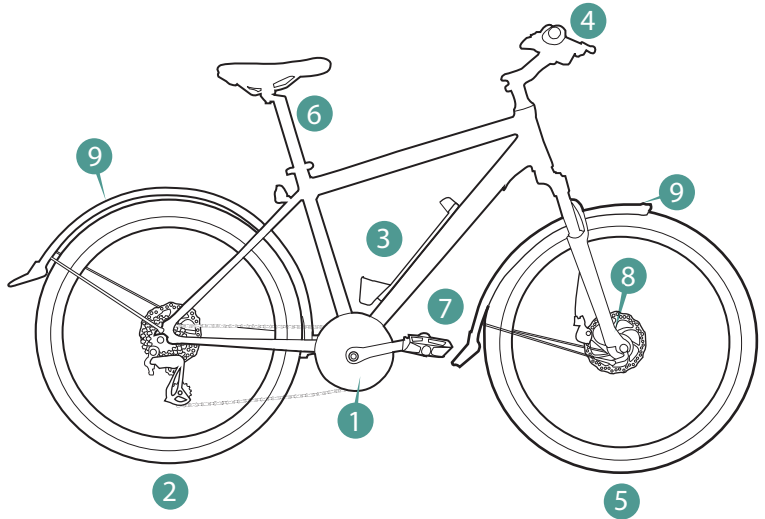

Note

The Battery & charger package is shipped separately for safety purposes

OWNER'S IDENTIFICATION

Each eProdigy bicycle frame, motor and battery has a unique serial number. The **1** Bike Frame Serial Number **2** Motor Serial Number and the **3** Battery Serial Number can be as shown here.

Record these numbers below to keep for future reference. If the bicycle is stolen, these serial numbers may help in retrieving the lost bike.

Frame Serial Number _____
Motor Serial Number _____
Battery Serial Number _____
Purchase Date _____
Model Name _____
Dealer _____

Note

*This information is only available on your products.
It is not available from eProdigy*

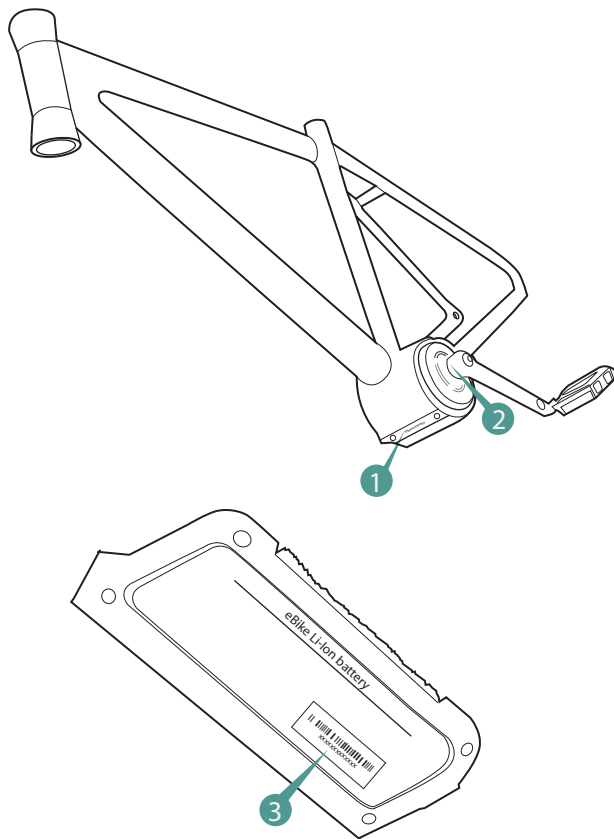

RECOMMENDED TOOLS

Our very own eProdigy technical team recommends the following tools to assemble the *Whistler* eBike

- 1 2.5mm, 3mm, 4mm, and 5mm Allen keys
- 2 Phillips screw driver
- 3 Crescent wrench and/or 10mm wrench
- 4 15mm pedal wrench
- 5 Bicycle grease

⚠ WARNING

Keep small parts away from children during assembly

Note

Do not dispose the carton or packaging until the assembly of the bicycle is complete. This can prevent accidentally discarding parts of the bicycle.

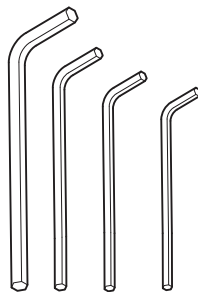

1



2

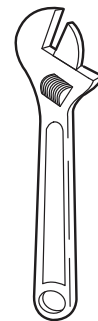

3

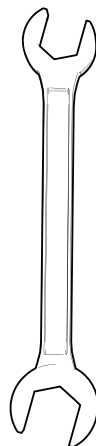

3

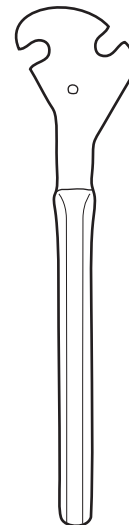

4

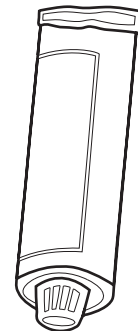

5

HANDLEBAR INSTALLATION

Use a Phillips screwdriver and 4mm Allen key

- 1 Use the 4mm Allen key to remove the **a** handlebar mount

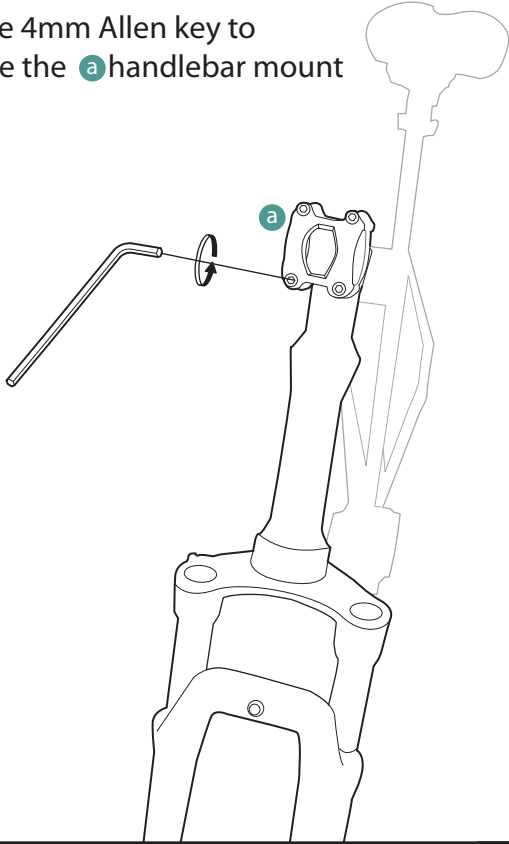

- 2 Center the handlebar to the stem and ensure the handlebar's direction is aligned with the front fork

- 3 Evenly tighten the mount screws with the 4mm Allen key

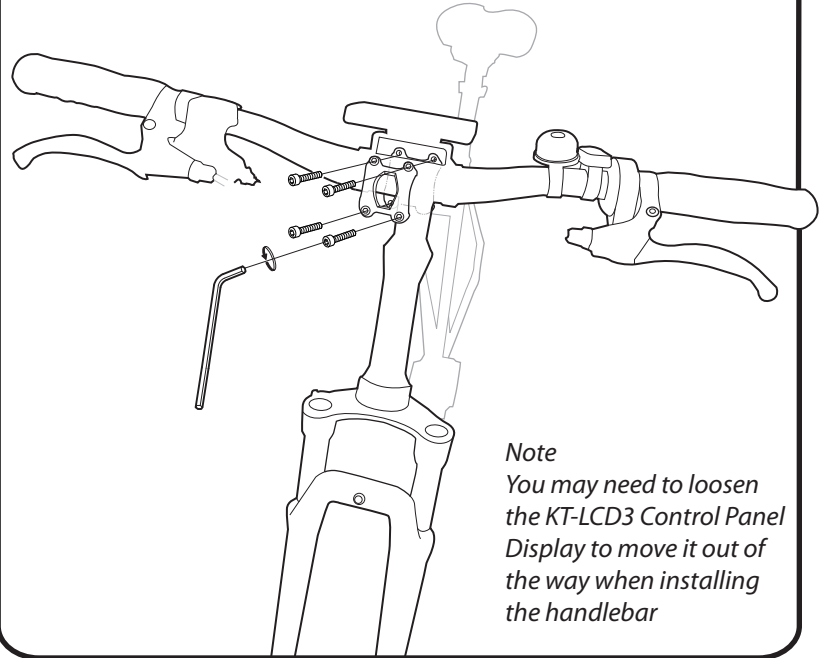

Note
You may need to loosen the KT-LCD3 Control Panel Display to move it out of the way when installing the handlebar

Top View

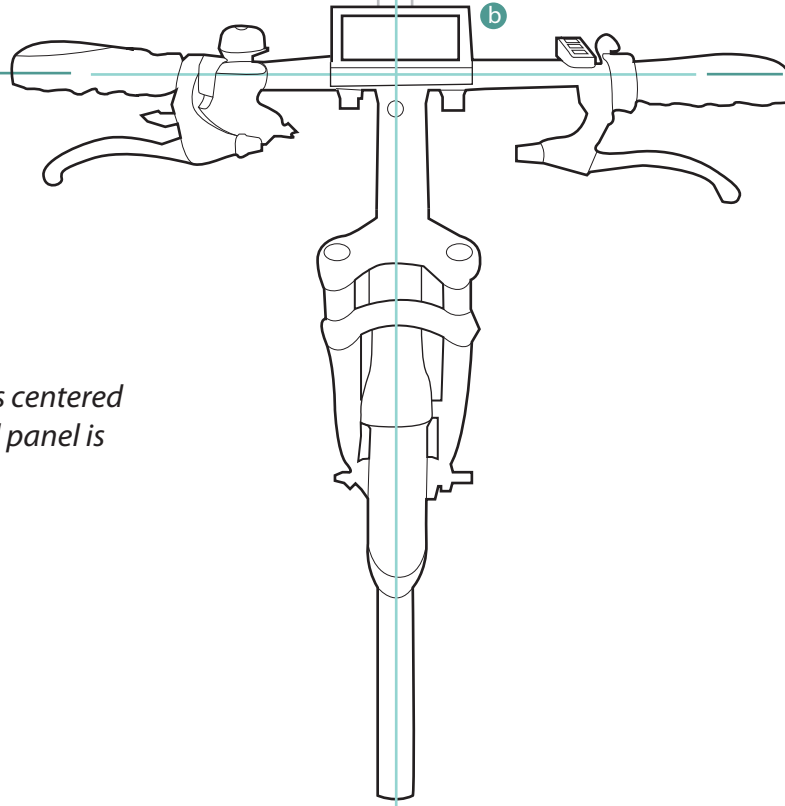

Note

Make sure the handle bar is centered and the **b** KT-LCD3 control panel is secure

FRONT WHEEL INSTALLATION

- 4 Place the wheel between the front fork

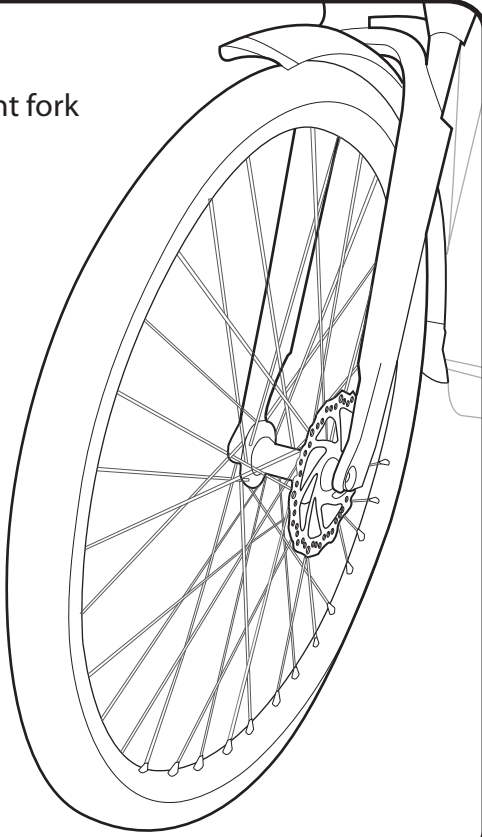

- 5 Make sure the **c** rotor is centered between **d** brake pads, rotating without friction

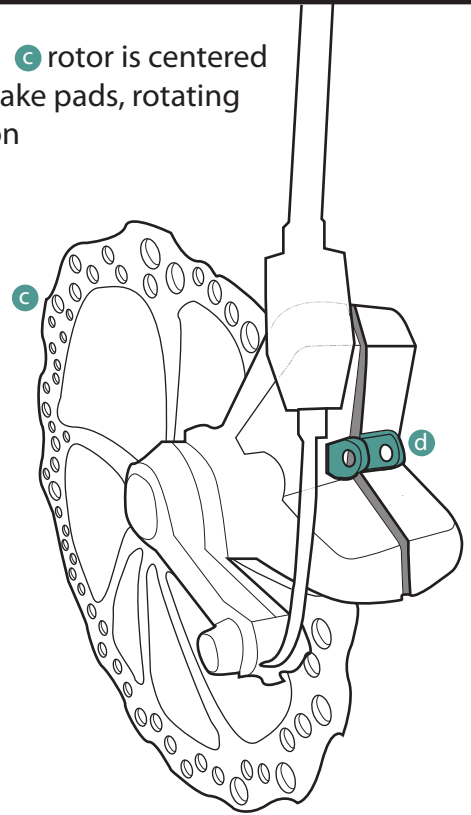

Note
consult your dealer for
replacement brake pads as needed

6 Install the quick release skewer through the front wheel

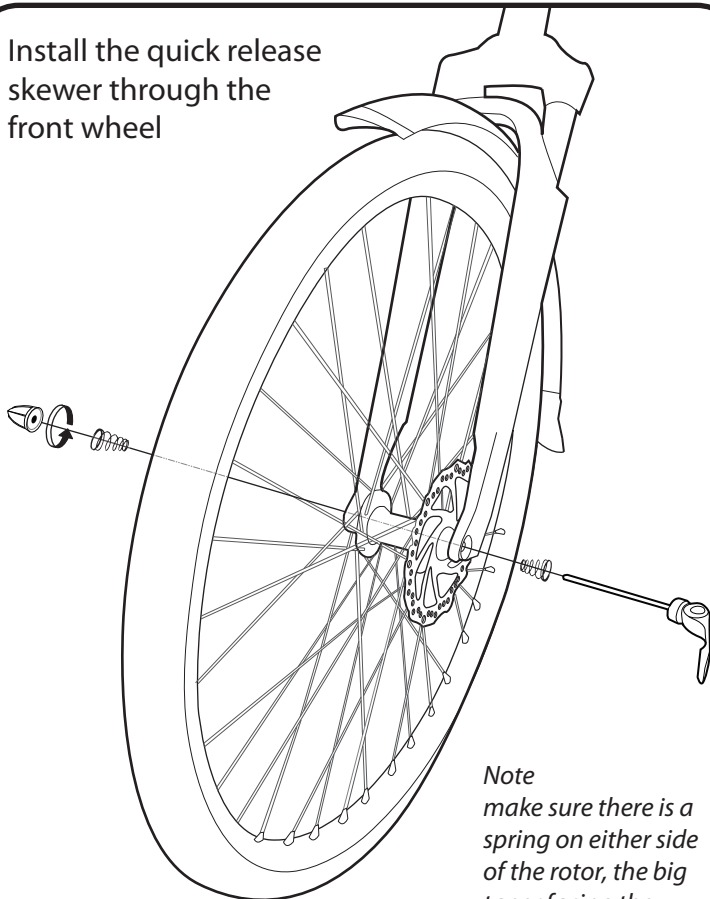

Note
make sure there is a spring on either side of the rotor, the big taper facing the outside of the wheel

7 In the lever open position, twist the **e** end cap on till snug. Then close the quick release lever to the closed position

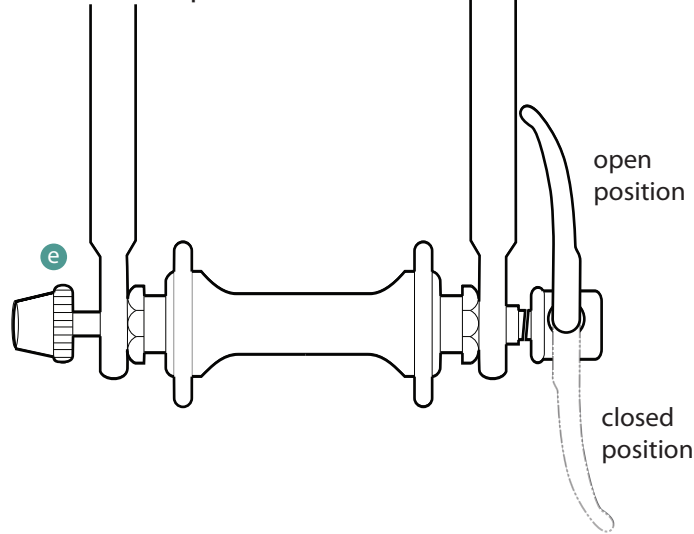

Note
Make sure quick release lever is on the opposite of the drive side

PEDALS INSTALLATION

Use 15mm pedal wrench, bicycle grease

* Each pedal is marked with a R or L to help make sure you are installing the correct side

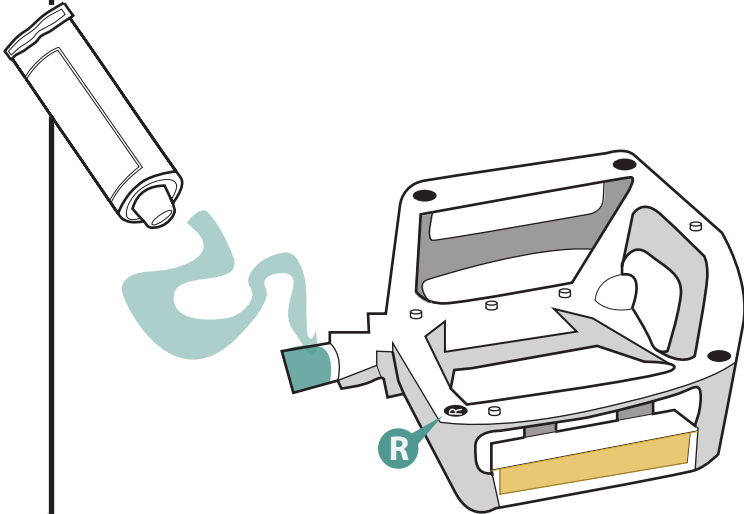

- 8 Apply grease onto the pedal threads

- 9 On the left side, tighten pedal counter-clockwise

- 10 On the drive side tighten pedal clockwise

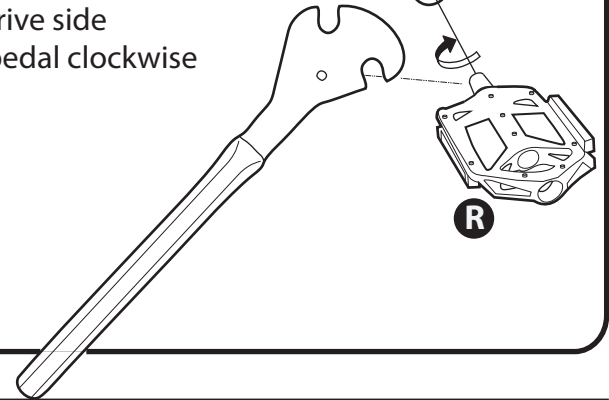

PUMP UP TIRES

Use a tire pump or a regulated air hose

- 11 Pump your tires to the optimal tire pressure; up to 50 PSI

Maintenance:

- *Frequently check the tire inflation pressure because all tires lose air slowly over time. For extended storage, keep the weight of the bicycle off the tires.*

- *Do not use unregulated air hoses to inflate the inner tubes. An unregulated hose can suddenly over inflate bicycle tires and cause them to burst.*

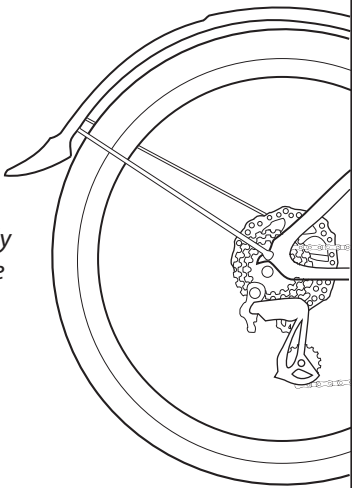

- 12 Apply grease evenly on the seat post before the bike's first ride

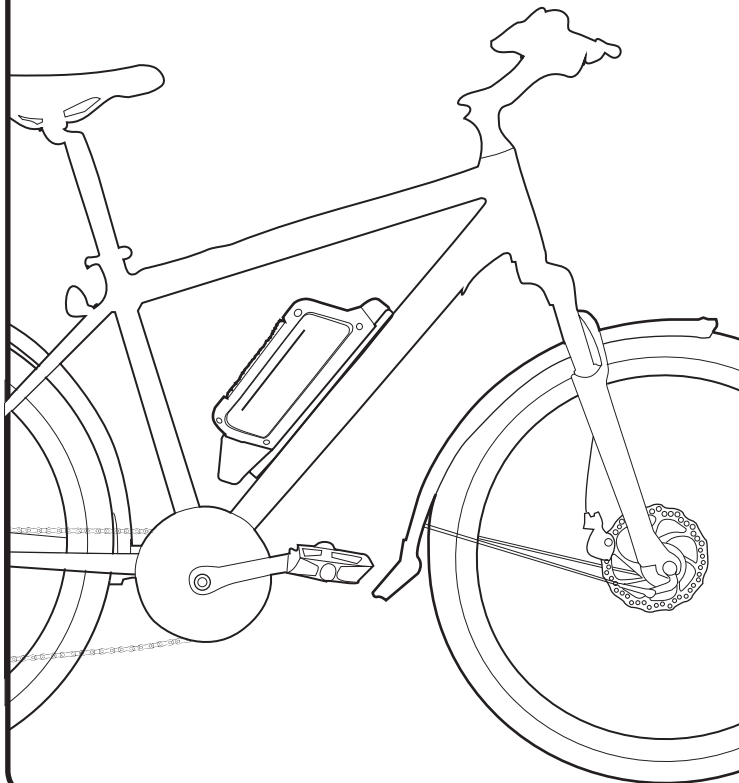

ABOUT THE BATTERY

General Overview

The eProdigy *Whistler* is proudly powered by Lithium Ion Cells produced by Dr. Battery®, a leader in producing innovative, sustainable power technologies. Li-Ion batteries do not have a memory effect, which means the battery's maximum energy capacity is not affected if it is repeatedly recharged after only being partially discharged. Complete drainage is not required before charging. This characteristics and their ability to hold a charge for long periods while maintaining a high energy density making them ideal for driving portable equipment. Through it's life cycle, as with all batteries, the Li-Ion cell will deteriorate from 100% capacity at full charge to approximately 80% over 800 cycles.

Battery Maintenance

Very little maintenance is required, however there are some key steps to ensure the optimal performance of your battery and the longest life span possible (approx. 2 years or 800 charge cycles).

WARNING

eProdigy will not be held liable for battery breakdown caused by improper care or misuse including, but not limited to opening the battery case. Battery damage due to user mishandling or neglect voids all warranty and product liability claims.

Storage

The battery should be stored in temperatures between 10°C (50°F)~ 25°C (77°F) and never colder than -10°C (14°F) or over 45°C (113°C). Exposing your battery to extreme temperature fluctuations or humidity will severely reduce battery life and potentially cause corrosion.

Charging and Handling Your Battery

We recommend charging your battery with an eProdigy charger at room temperature after every ride, ideally when the battery is at less then 50% charge. If it has been exposed to cold temperatures, wait until it warms to about 20°C before charging.

Mounting and Removing the Battery Pack

The battery is an important and costly component of an eBike. It is designed to be locked into position with a key to prevent theft. Always make sure that all settings are switched off before removing the battery. Routinely wipe dry and clean the battery connectors on the battery mount.

Inserting Down-Tube Battery

- 1 align the battery with track on the docking station
- 2 insert the battery pack into the down-tube mount
- 3 you will hear a "click" when the battery lock is secure

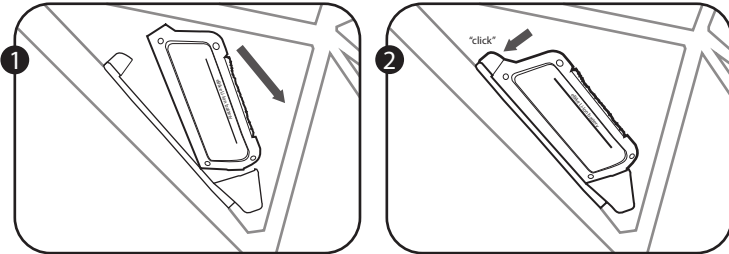

CAUTION

Do not force the battery onto the battery dock.
This can damage the battery connector.

Removing Down-Tube Battery

- 1 turn off the Motor by shutting off the KT-LCD3 display (no image shown)
- 2 insert the key and turn clockwise, gently pull the handle outwards to lift the battery from the dock

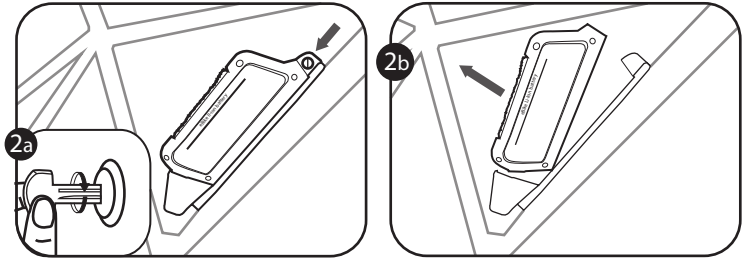

Note

The battery pack can be heavy, so be careful not to drop it

Charging Procedure

- 1 connect the charger to the battery, ensure connections are secure
- 2 insert the charger cable into an AC outlet
- 3 if the power plug is inserted without the battery connected to the charger, the LED will light up green, signifying it's STANDBY status

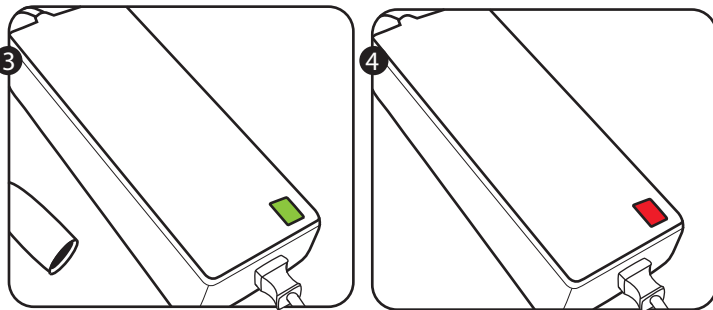

- 4 to signify it's CHARGING status, the LED will light up red
- 5 to signify it's FULLY CHARGED status, the LED will light up green

Note

when the battery is fully charged, the voltage reading should be approximately 40 volts

⚠ WARNING

Do not leave a charging battery overnight or unattended, to avoid overheating. It generally takes 4-6 hours to fully charge a completely drained battery.

Checking the Battery state-of-charge

Located on the body of the battery is State-of-Charge LED indicator.

- 1 press down on  till you hear a "click"
- 2 battery state-of-charge LED will illuminate



100-75% charge



50-25% charge



75-50% charge



<25% charge

